

AS-WQ Series

Product Overview

1. Submersible sewage pump is latest model sewage discharge equipments designed and manufactured on the basis of the advanced pump technology from Germany and so on.

2. Drainage cutter pump Especially suitable for transmission the liquids that contain solid and fiber matters, and dirty, stick slippery liquid. With the cutting device installed inside in advance, all WQK septic tank pumps submersible sewage pump can tear off the long fiber matters, such as bags, belt, grass and cloth, and then discharge it with water. Therefore, it can run more smoothly and reliable in waste water, without being blocked.



The Main Purpose

It is suitable for sewage cutter pump for septic tank biogas digester

Material

1. Motor: 100% copper wire inside, full power.
2. Mechanical seal: alloy and silicon carbide
3. Shaft: 45# steel and stainless steel as your option
4. Screw: stainless steel

High Chrome Impeller

Pump Drawing

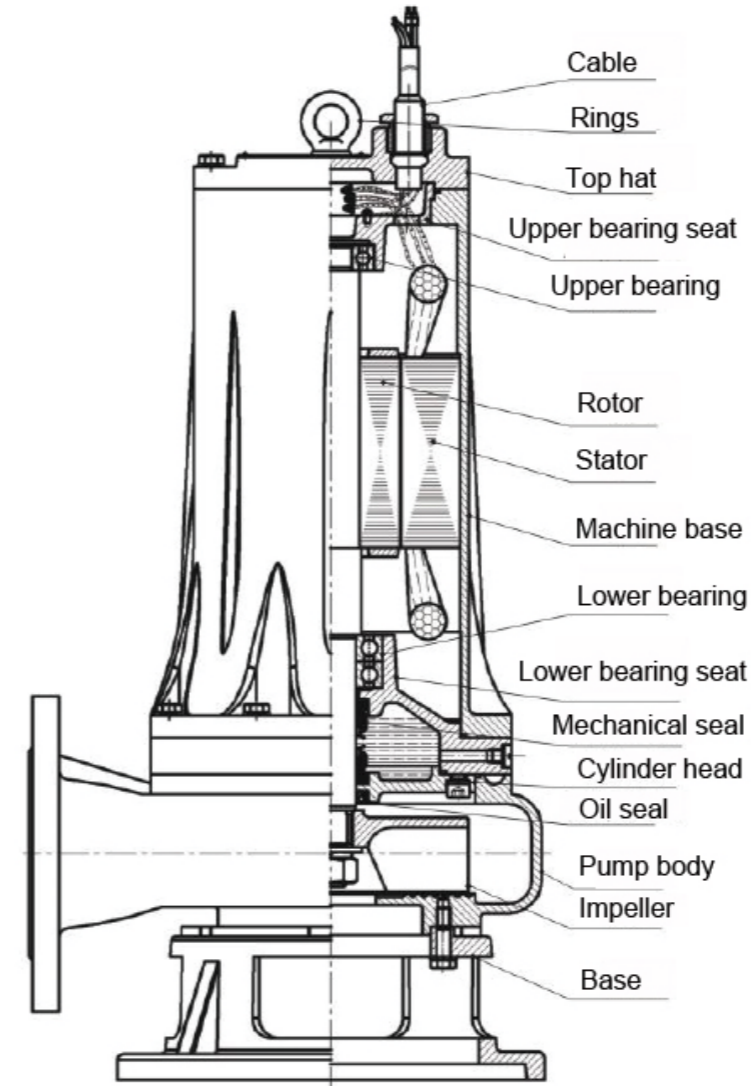

Model	Power		Rated Flow m³/h	Rated Head m	Outlet Size inch	Speed rpm	Model	Power		Rated Flow m³/h	Rated Head m	Outlet Size inch	Speed rpm
	kw	HP						kw	HP				
80ASWQ100-25-11	11	15	100	25	3	1450	100ASWQ120-50-37	37	50	120	50	4	1450
100ASWQ100-25-11	11	15	100	25	4	1450	150ASWQ200-35-37	37	50	200	35	6	1450
150ASWQ180-11-11	11	15	180	11	6	1450	250ASWQ600-12-37	37	50	600	12	10	1450
200ASWQ300-7-11	11	15	300	7	8	1450	300ASWQ800-9-37	37	50	800	9	12	1450
250ASWQ400-5-11	11	15	400	5	10	1450	100ASWQ100-57-45	45	61	100	57	4	1450
80ASWQ100-30-15	15	20	100	30	3	1450	150ASWQ200-40-45	45	61	200	40	6	1450
100ASWQ100-30-15	15	20	100	30	4	1450	200ASWQ300-32-45	45	61	300	32	8	1450
150ASWQ200-15-15	15	20	200	15	6	1450	200ASWQ400-25-45	45	61	400	25	8	1450
200ASWQ250-11-15	15	20	250	11	8	1450	250ASWQ600-15-45	45	61	600	15	10	1450
250ASWQ500-5-15	15	20	500	5	10	1450	300ASWQ800-12-45	45	61	800	12	12	1450
80ASWQ100-35-18.5	18.5	25	100	35	3	1450	100ASWQ100-65-55	55	75	100	65	4	1450
100ASWQ100-35-18.5	18.5	25	100	35	4	1450	150ASWQ180-50-55	55	75	180	50	6	1450
150ASWQ180-20-18.5	18.5	25	180	20	6	1450	200ASWQ300-40-55	55	75	300	40	8	1450
200ASWQ250-15-18.5	18.5	25	250	15	8	1450	200ASWQ400-30-55	55	75	400	30	8	1450
200ASWQ350-10-18.5	18.5	25	350	10	8	1450	250ASWQ600-20-55	55	75	600	20	10	1450
250ASWQ500-7-18.5	18.5	25	500	7	10	1450	300ASWQ800-15-55	55	75	800	15	12	1450
300ASWQ650-5-18.5	18.5	25	850	5	12	1450	150ASWQ200-60-75	75	102	200	60	6	1450
80ASWQ100-40-22	22	30	100	40	3	1450	200ASWQ350-45-75	75	102	350	45	8	1450
100ASWQ100-40-22	22	30	100	40	4	1450	250ASWQ600-25-75	75	102	600	25	10	1450
150ASWQ200-22-22	22	30	200	22	6	1450	300ASWQ800-20-75	75	102	800	20	12	1450
200ASWQ300-16-22	22	30	300	16	8	1450	150ASWQ200-70-90	90	122	200	70	6	1450
200ASWQ400-10-22	22	30	400	10	8	1450	200ASWQ300-60-90	90	122	300	60	8	1450
250ASWQ500-9-22	22	30	500	9	10	1450	200ASWQ400-50-90	90	122	400	50	8	1450
300ASWQ650-7-22	22	30	850	7	12	1450	250ASWQ600-30-90	90	122	600	30	10	1450
100ASWQ120-45-30	30	40	120	45	4	1450	300ASWQ800-25-90	90	122	800	25	12	1450
150ASWQ180-30-30	30	40	180	30	6	1450	150ASWQ180-80-110	110	150	180	80	6	1450
200ASWQ250-22-30	30	40	250	22	8	1450	200ASWQ300-65-110	110	150	300	65	8	1450
250ASWQ500-12-30	30	40	500	12	10	1450	250ASWQ600-40-110	110	150	600	40	10	1450
250ASWQ600-9-30	30	40	800	9	10	1450	300ASWQ1000-25-110	110	150	1000	25	12	1450
300ASWQ800-7-30	30	40	800	7	12	1450							

Model	Power		Rated Flow m³/h	Rated Head m	Outlet Size inch	Speed rpm	Model	Power		Rated Flow m³/h	Rated Head m	Outlet Size inch	Speed rpm
	kw	HP						kw	HP				
80WQAS60-30-11	11	15	80	30	3	2900	200WQAS180-15-15	15	20	180	15	8	2900
100WQAS80-25-11	11	15	80	25	4	2900	80WQAS60-45-18.5	18.5	25	80	45	3	2900
150WQAS100-20-11	11	15	100	20	6	2900	100WQAS80-40-18.5	18.5	25	80	40	4	2900
150WQAS120-15-11	11	15	120	15	6	2900	150WQAS100-36-18.5	18.5	25	100	36	6	2900
200WQAS180-11-11	11	15	180	11	8	2900	200WQAS180-18-18.5	18.5	25	180	18	8	2900
80WQAS60-40-15	15	20	80	40	3	2900	80WQAS60-50-22	22	30	80	50	3	2900
100WQAS80-35-15	15	20	80	35	4	2900	100WQAS80-45-22	22	30	80	45	4	2900
150WQAS100-30-15	15	20	100	30	6	2900	150WQAS100-40-22	22	30	100	40	6	2900
150WQAS120-25-15	15	20	120	25	6	2900	200WQAS200-20-22	22	30	200	20	8	2900

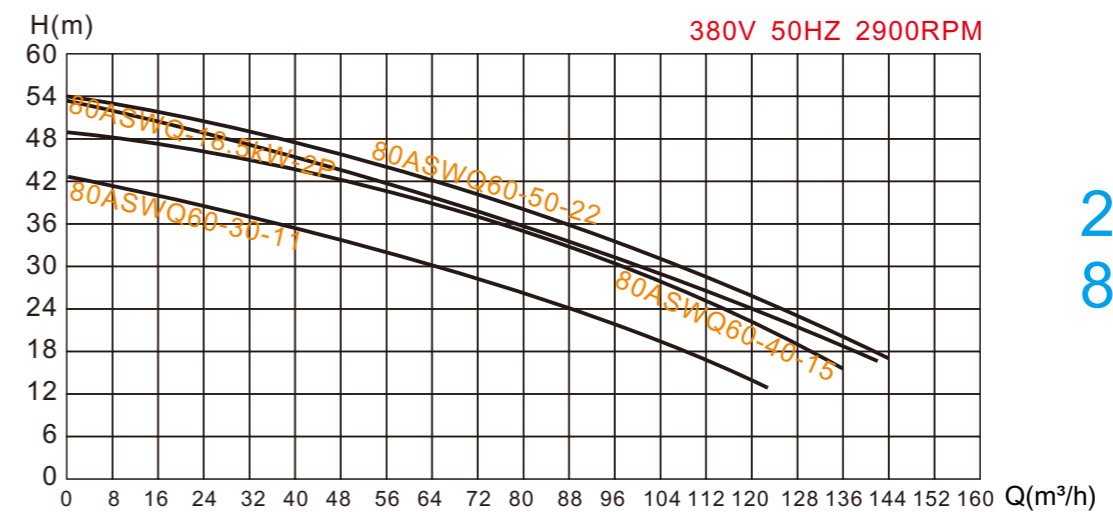
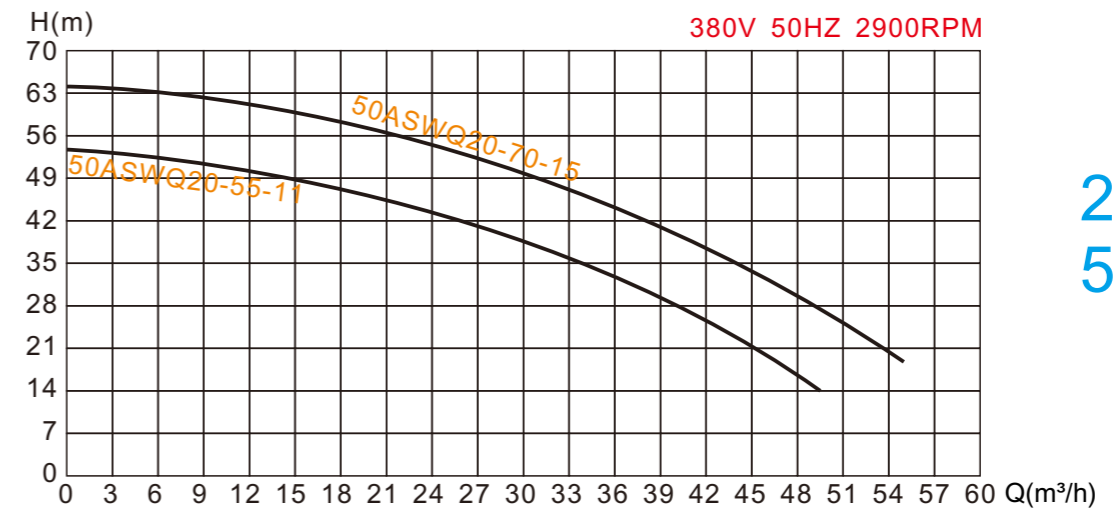

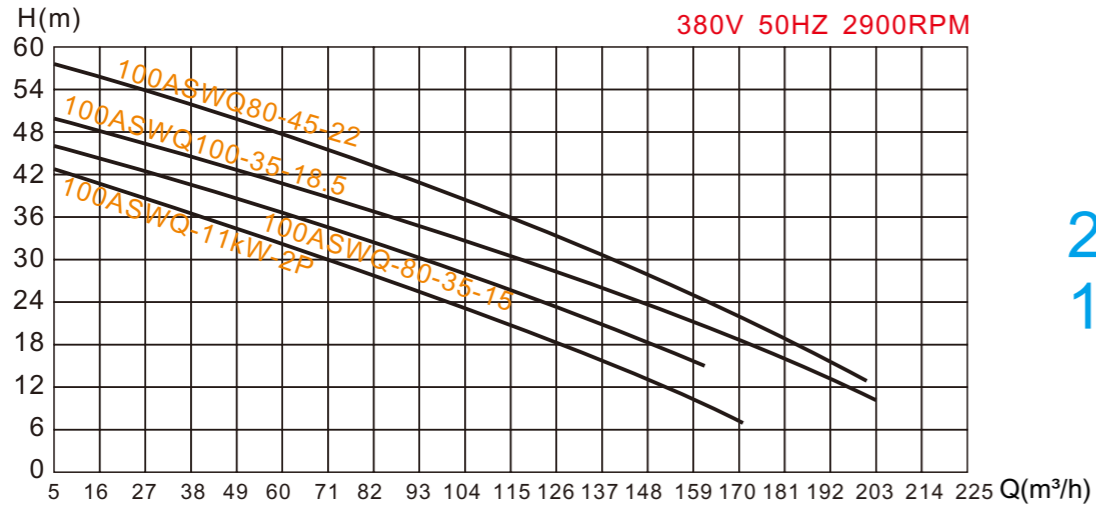

**2 Pole
100 Inch**

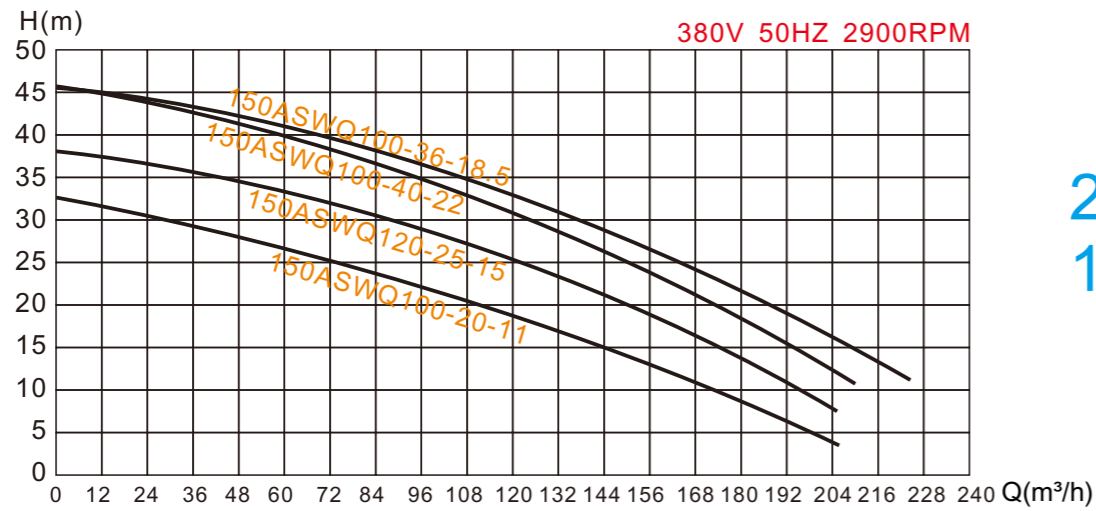

**2 Pole
150 Inch**

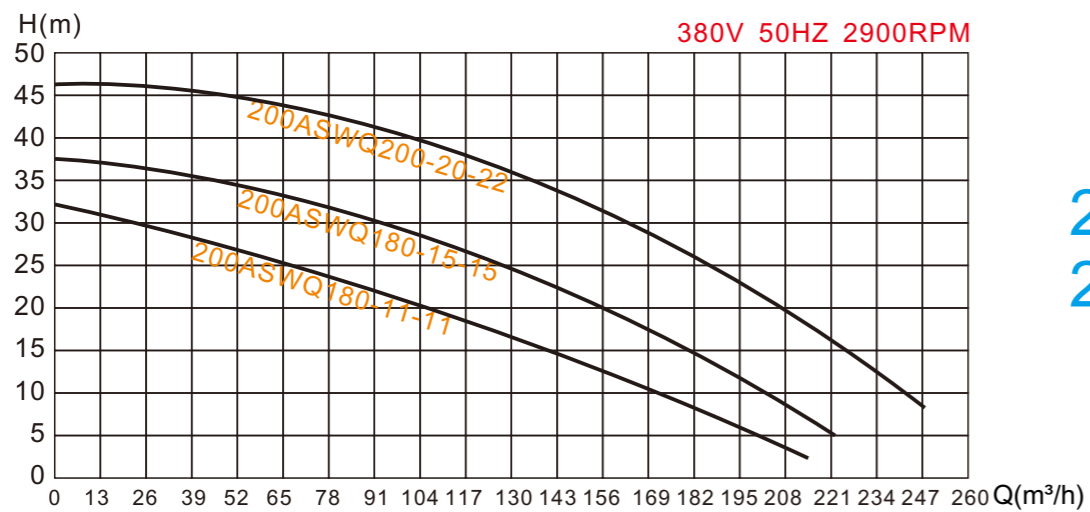

**2 Pole
200 Inch**

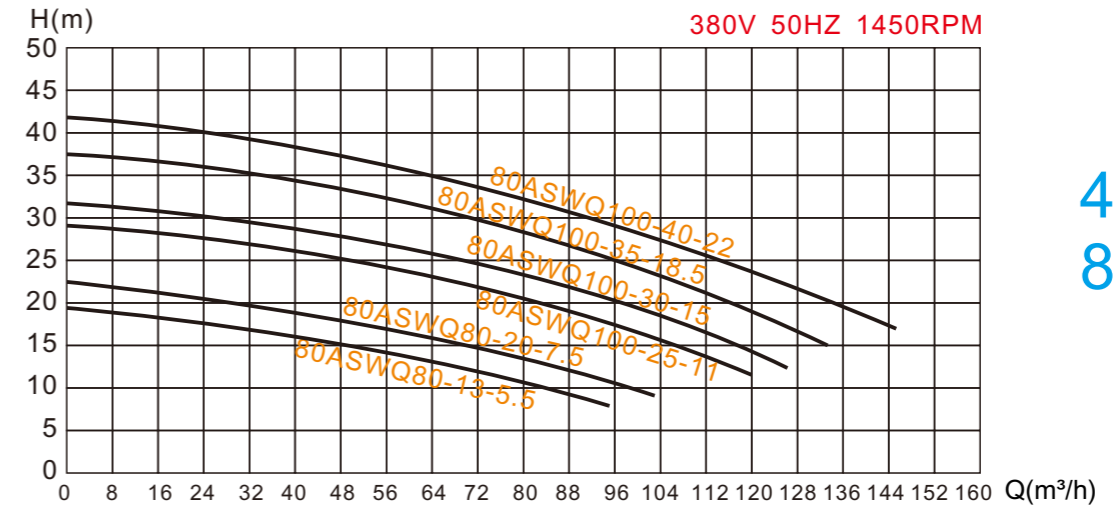

**4 Pole
80 Inch**

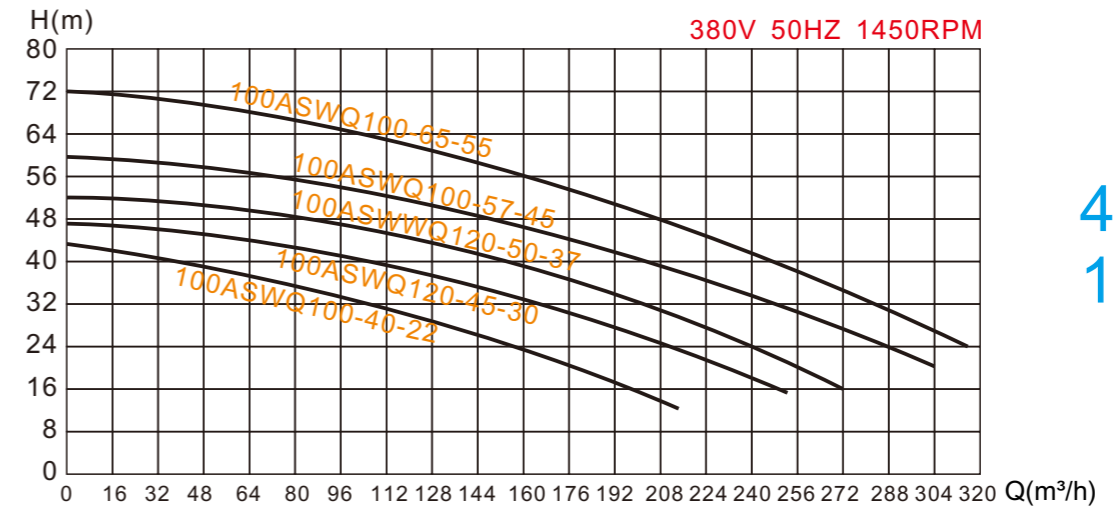

**4 Pole
100 Inch**

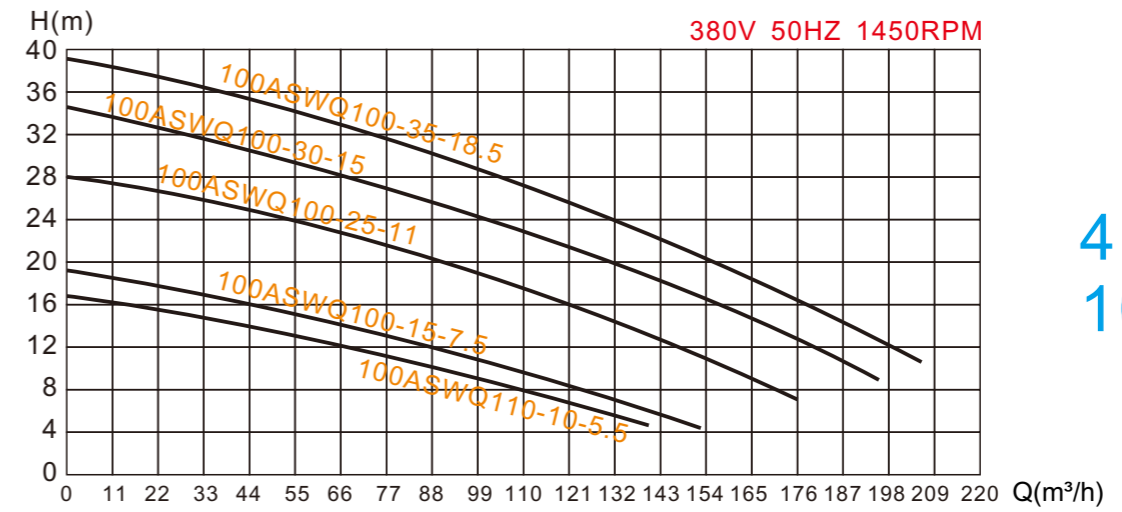

**4 Pole
100 Inch**

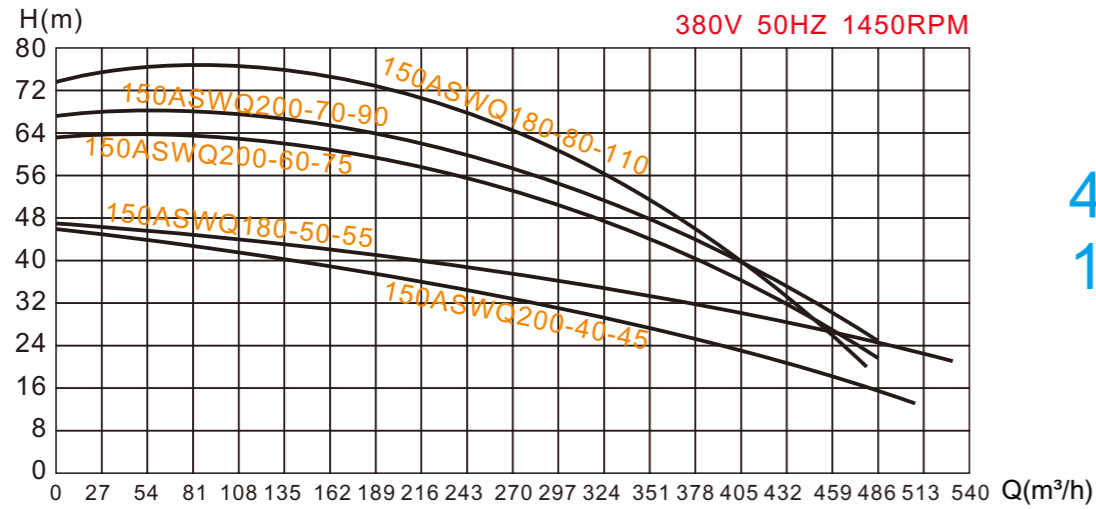

4Pole
150Inch

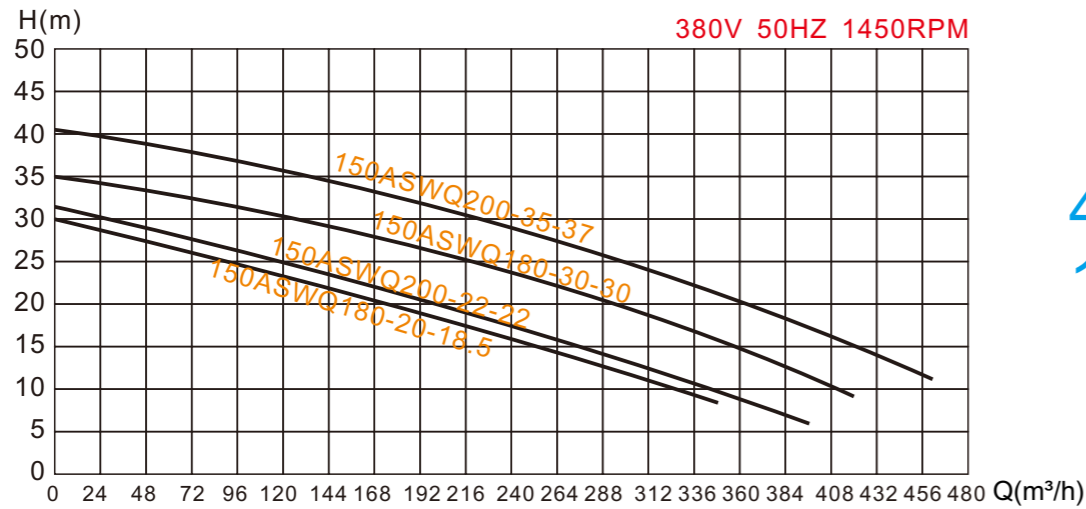

4Pole
150Inch

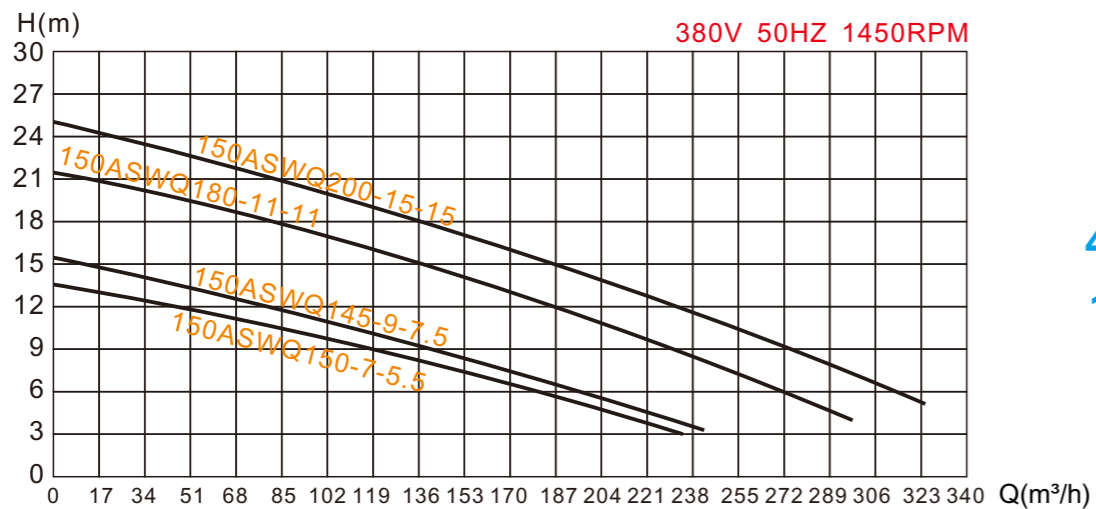

4Pole
150Inch

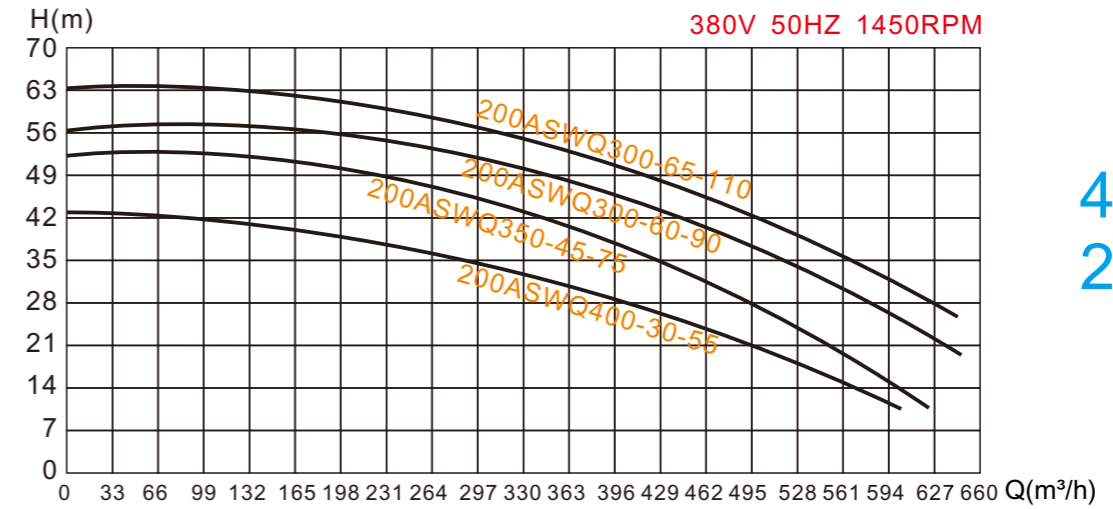

4Pole
200Inch

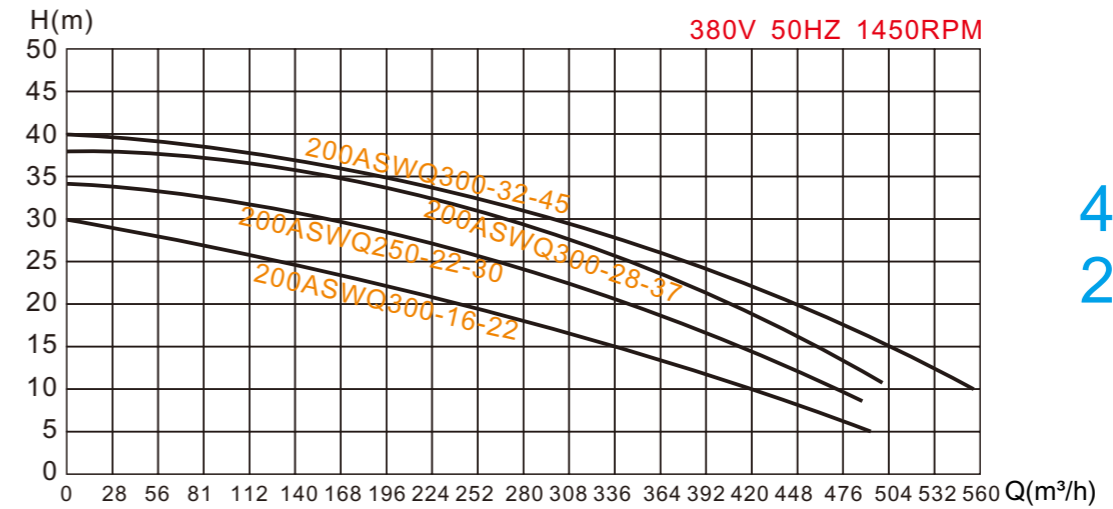

4Pole
200Inch

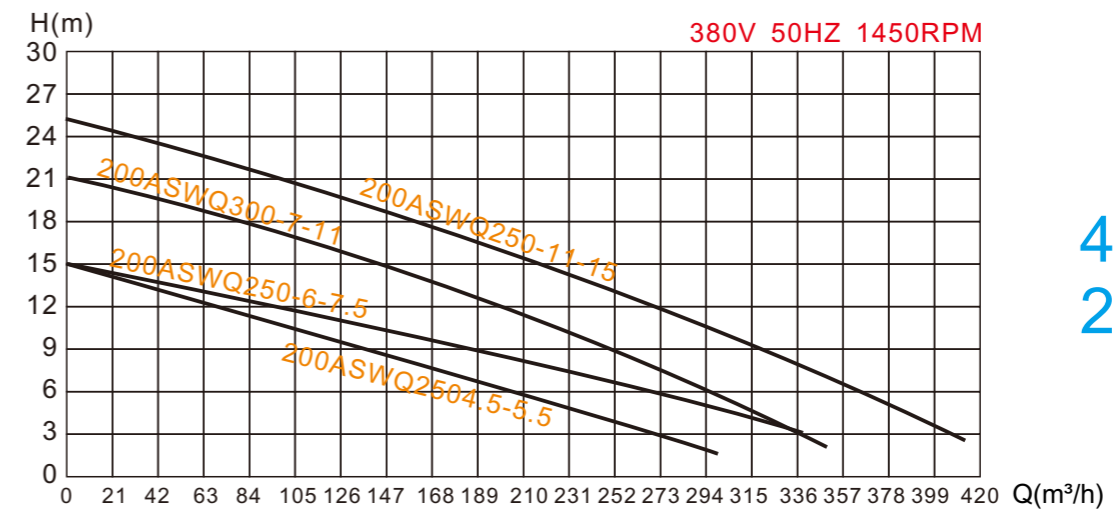

4Pole
200Inch

